

# NGN/IMS solutions



# Company profile

Protei is a leading Telecom Solutions provider for a wide variety of products including Core network, Roaming, Messaging, VAS, and customer service.

Operating in Europe, Central Asia, Latin America, Russia, the Middle East, and North Africa; Protei has extensive know-how and a proven track record from 2002 in the telecommunication market.

More than 400 customers are relying on our innovative platforms, which provide Reliability, Scalability, Flexibility, and Adaptability with the highest perspective of tailor-made flexibility that increases revenue improves customer experience and reduces costs. Headquartered in Tallinn Estonia, Protei has global office in Amman—the Hashemite Kingdom of Jordan.







The Jordan-based Protei MENA branch was founded in 2009 to better support Protei's Regional clients. Protei MENA is the base of Protei's high caliber and well-trained Arabic-speaking professionals.

MENA branch Delivered 100+ New/Replacement projects in several MENA operators within the last eleven years.

PROTEI serves more than 400 renowned customers in over 35 countries to cater+ 300 million subscribers worldwide. PROTEI employs more than 600 highly skilled professionals of whom approximately 70% are involved in research and development.

PROTEI specializes in creating solutions that take full advantage of the most advanced available technologies, designed in-house with strict quality control based on ISO9001:2001 and ISO14001: 2004, rigorous testing for stability and reliability with the maximum compatibility with all our existing product range.

PROTEI product line includes:

-  Mobile solutions (CS and PS Core solutions, EPC, Messaging Solutions, Roaming Solutions, Location Based Services,
-  IN&CAMEL solutions, VAS platforms).
-  Customer Care and Call center solutions (IVR based services, IP Call center).
-  NGN/IMS solutions.
-  Traffic Management and Policy Control Solutions (DPI, PCRF).
-  Billing System, Online/Offline Charging System (OCS/OFCS), CRM.
-  OT, Private LTE and Safe City.

# NGN/IMS solutions

PROTEI NGN/IMS equipment is high-quality, industry-grade systems enabling the Operator to launch the full range of NGN services with specified QoS. Our systems are the best choice for Operators aimed to create or migrate their network to IP technology.

PROTEI offers a full line of carrier-class equipment for providing both switching services and VAS. Soft switches Class 4,5, VoIP gateways, Access equipment, IP-PBX, service platforms de-signed by PROTEI have been installed in networks of the largest Russian and CIS Operators.

PROTEI NGN/IMS product line provides not only a major increase in range and quality of services available to subscribers but also brings about a considerable reduction of network Operating costs.

## Key Benefits

- Carrier class field proven solutions;
- Reliable and cost-effective hardware and software platform;
- More than 1000 installations all over the world;
- Embedded LI-functionality;
- Hardware developed by PROTEI;
- Easy integration and adaptation to customers' needs;
- Virtual environment on Operator's hardware;
- Horizontal scaling;
- High reliability without single "failure point";
- Long warranty period;
- 24x7x365 support service;
- Free-of-charge initial training;
- Full remote access to the system components.

# IMS Core

PROTEI develops IP multimedia subsystem (IMS) products as multi platform applications which form the mobile services core network. PROTEI IMS solutions can be easily deployed on various hardware devices/servers and cover full range of voice services for subscribers, for example RCS. PROTEI IMS product range includes Proxy-Call Session Control Function (P-CSCF), Serving/Interrogating Call Session Control Function (S/I-CSCF), HSS, AS, MGW.

PROTEI IMS solutions focus on voice and video calls with high audio quality, low delays and high reliability. The high-speed data transmission can be also used while talking. In some cases, IMS Core deployment assumes much investment in the first phase. However, NFV technology using in PROTEI IMS Core allows to use existing resources for launching small vIMS systems with minimum expenses and forces from the Operator.

The solution developed is fully compliant with 3GPP International Specifications TS 23.228, TS 23.218, TS 23.229, TS 24.229, TS 29.228, TS 29.229, TS 29.949.

## Key Benefits

- Virtualized Solution deployable in Cloud/NFV environment;
- Effective tool to reduce costs for launching and maintaining perspective IP Services;
- Compliance with 3GPP standards;
- Simultaneous voice and data, effective migration to all-IP;
- Multi-scenario deployment;
- Distributed architecture;
- Flexible licensing scenarios;
- Easy integration with external HSS and GGSN/PGW;
- Advanced administration and maintenance interface.

## Features

- Support of fixed and mobile subscribers from 50 to 200,000 concurrently connected subscribers per one module;
- Virtualization and horizontal scaling support;
- Non-IMS SIP devices support (like SIP IETF/IP-PBX devices);
- 3GPP interfaces, procedures and ref. points;
- IMS ISC interfaces, IFC with third-party AS support;
- Flexible increasing of system capacity according to Operator's needs;
- PROTEI IMS elements can be enabled/disabled without any interruption in service providing;
- Interaction with external HSS and GGSN/PGW via standard interfaces is supported;
- Licensing model is based on number of active subscribers;
- Virtualized Solution is deployable in Cloud/NFV environment;
- Embedded administration and maintenance subsystem reduces the complexity of the network layout and presents an easy management tool with CLI/SNMP support;
- All PROTEI IMS Core element supports full set of 3GPP interfaces, that allows to integrate PROTEI solution into any telecom environment;
- Throughput values for system components are:
  - HSS – up to 10M subscribers;
  - PCSCF/ASBC – up to 5k call sessions per module (including ALG);
  - S/I-CSCF – up to 100k subscribers.
- CDR generation for calls, registrations and statistics.

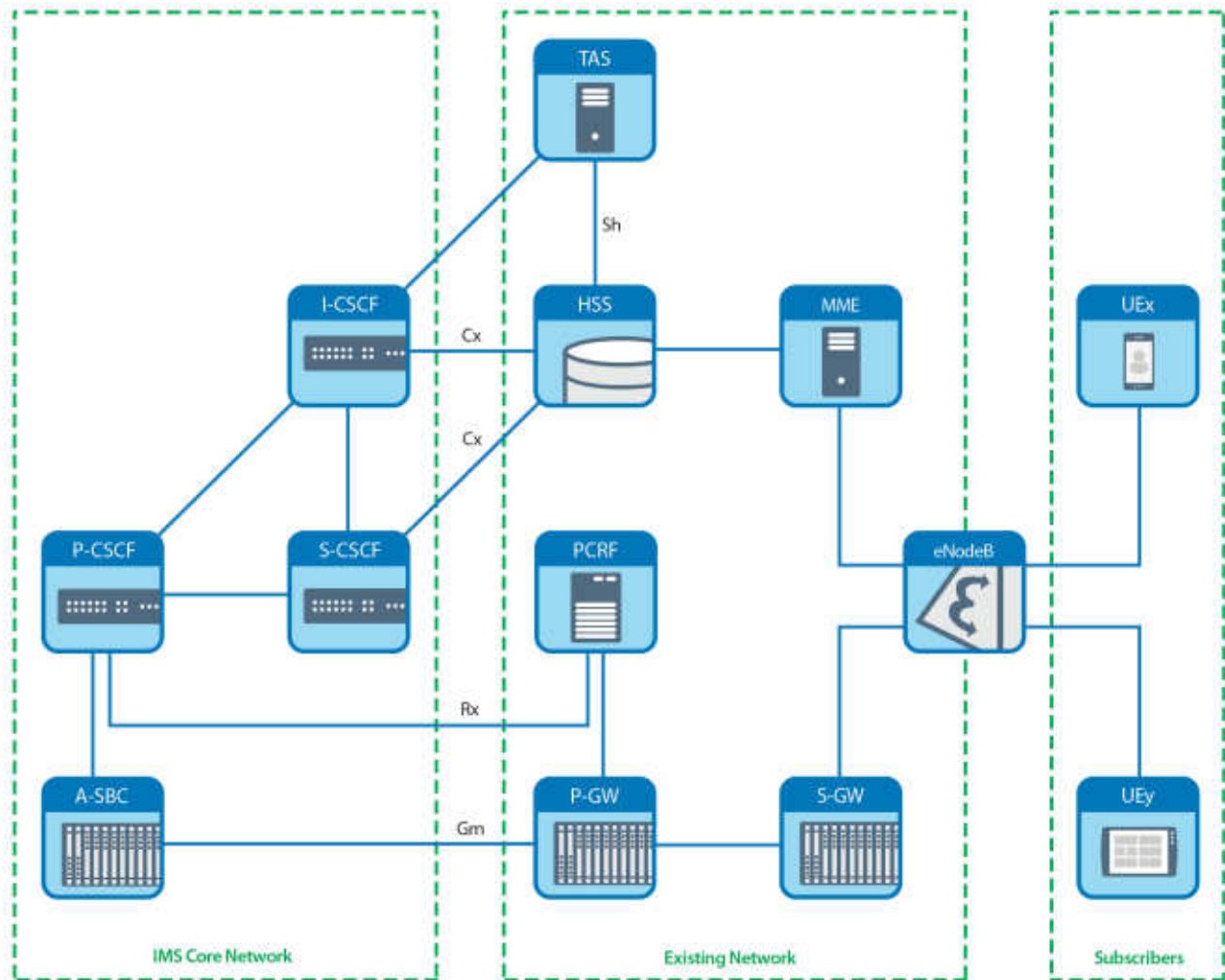

**IMS CSCF (Call Session Control Function)** is intended to provide the registration procedures of terminal equipment and SIP routing.

**Proxy-CSCF** is an access point for IMS/SIP devices in IMS Core network. P-CSCF acts as a proxy server for the user equipment and all signaling traffic from/to user terminals pass through it. P-CSCF provides device interworking security measures and QoS management with Policy Control Function. It prevents network from attacks, protects subscriber privacy and generates charging records.

**Interrogating-CSCF** is a session control entity for endpoint devices. It also retrieves address of S-CSCF from HSS and forward SIP requests/responses from/to it. IP addresses are stored in DNS server as A or SRV records. As a part of IBCF, it is used as gateway to external networks and connected to BGCF.

**MGW (Media Gateway)** is an entity for performing MRF and IMS-AGW/ALG functions. It interworks with signaling level and manages media resources for various media gateways. It can also include a BGCF module which provides routing from S-CSCF if routing criteria based on phone numbers. PROTEI-MGW supports H.248/SIP/H.323/SS7/PRI.

**Serving-CSCF** performs session control and operates with subscribers' profile information from HSS. It handles SIP registrations, fulfills third-party registration to various AS. All signaling traffic from/to registered subscribers pass through S-CSCF. It selects AS where SIP messages should be forward to provide the required services in accordance with the IFC information. Usually, there are more than one S-CSCF in the IMS network for granting a high availability and load distribution.

**HSS (Home Subscriber Server)** is a central database that contains user and subscription-related information. HSS stores user parameters, authentication information and list of services allowed for users. It also contains the subscriber profile such as QoS profile, access restrictions and roaming capabilities. PROTEI HSS may include an Authentication Center (AuC) that generates authentication vectors and security keys.

**AS (SIP Application server)** is an execute platform and interface with the S-CSCF via SIP. Its standard nowadays is based on VoLTE and RCS services and it allows the Operators interconnecting several networks using supplementary services with full media capabilities.

# Softswitch Class 5

PROTEI ImSwitch5 (Softswitch class 5) is a carrier class field proven platform for business and residential VoIP routing. It is intended for end users requiring local and long distance VoIP telephony services and primarily deals with subscription telephone services and route calls through local areas.

ImSwitch5 is a perfect solution for any business looking for an efficient telephone service platform that increases revenue and supports an extensive variety of applications. It provides more than 30 services, including Unified Communication (Voice, Video, IM, Presence). The number of services can be easily increased with the use of external intelligent network platforms.

Using PROTEI ImSwitch5 Operators can deliver to users a wide range of services with maximum efficiency and make sure that customers stay loyal. Wide range of supported signaling systems makes it ideal for use on the boundaries of networks with different protocols. Functionality of softswitches class 4 and 5 can be effectively combined in our solution using the single software and hardware platform. Outstanding flexibility makes PROTEI ImSwitch5 suitable for applications ranging in scale from offices to national networks. Using PROTEI ImSwitch5 allows the Operator to raise income due to new NGN/IMS services implementation.

## Functionality

- Powerful routing subsystem with scripting language for routing definition;
- Virtual PBX services including WEB-interface for virtual PBX self-administration;
- Any type of numbering plans;
- Call Authentication, Charging and Routing;
- RADIUS support;
- CDR generation and set of statistic counters;
- Active/Standby redundancy;
- SNMP for alarm indication;
- Wide list of supplementary services (conditional and unconditional forwarding, transfer, hunt and pick-up groups, conference, video calls etc);
- Convenient system administration and configuration management tools;
- Possibility to work with voice (RTP) proxying;
- Open interface (SIP) for interacting with appli-

cation servers (intellectual platform);

- SIP-register functionality support for all subscriber devices;
- Wide list of compatible devices (SIP telephones, softphones, FXS gateways, trunk gateways);
- MCU subsystem to support conference-calls;
- Can be used in IMS environment as IMS telephony application server;
- Key system elements redundancy (Active/Standby);
- Embedded LI functionality (can be adapted according to national requirements).

## Basic Features

- Direct Call;
- Call Waiting (CW);
- Call Transfer (CT);
- Call Forwarding Unconditional (CFU);
- Conditional Call Forwarding: CFB, CFNR;
- Set, change or reset passwords;
- Outgoing Call Barring;
- Call Forwarding using a password;
- Do Not Disturb feature;
- Incoming Call Notification;
- Conference Call;
- Consultation Call;
- Multi-level IVR;
- Call Recording;
- Voicemail;
- WEB2Fax, Fax2Email;
- Presence;
- Messaging (SIP message);
- Video Call;
- Malicious Call Identification (MCID);
- Own Calling Number Announcement (OCNA);
- Abbreviated Dialing (AD);
- Music on Hold (MOH);
- Auto Redial (CCNR);
- Call Waiting (CW);
- Call Holding with Callback feature;
- Set/clear number from black list;
- Multiple Subscriber Number (MSN);
- Calling Line Identification Presence (CLIP);

- Calling Line Identification Restriction (CLIR);
- Call switching for reference;
- Consult Call Transfer;
- Hunt and Pickup Group;
- Voice Chat Room;
- Subscriber-group connection (CUG);
- Selective call rejection;
- Hot Dial/ FDCI;
- Cancel all services.

## Enhanced Features

- Independent Abbreviated Numbering plans for separate vPBX;
- Individual IVR and music on-hold for each vPBX;
- Advanced statistics and monitoring subsystem;
- SNMP for alarm indication;
- API for Call Control.

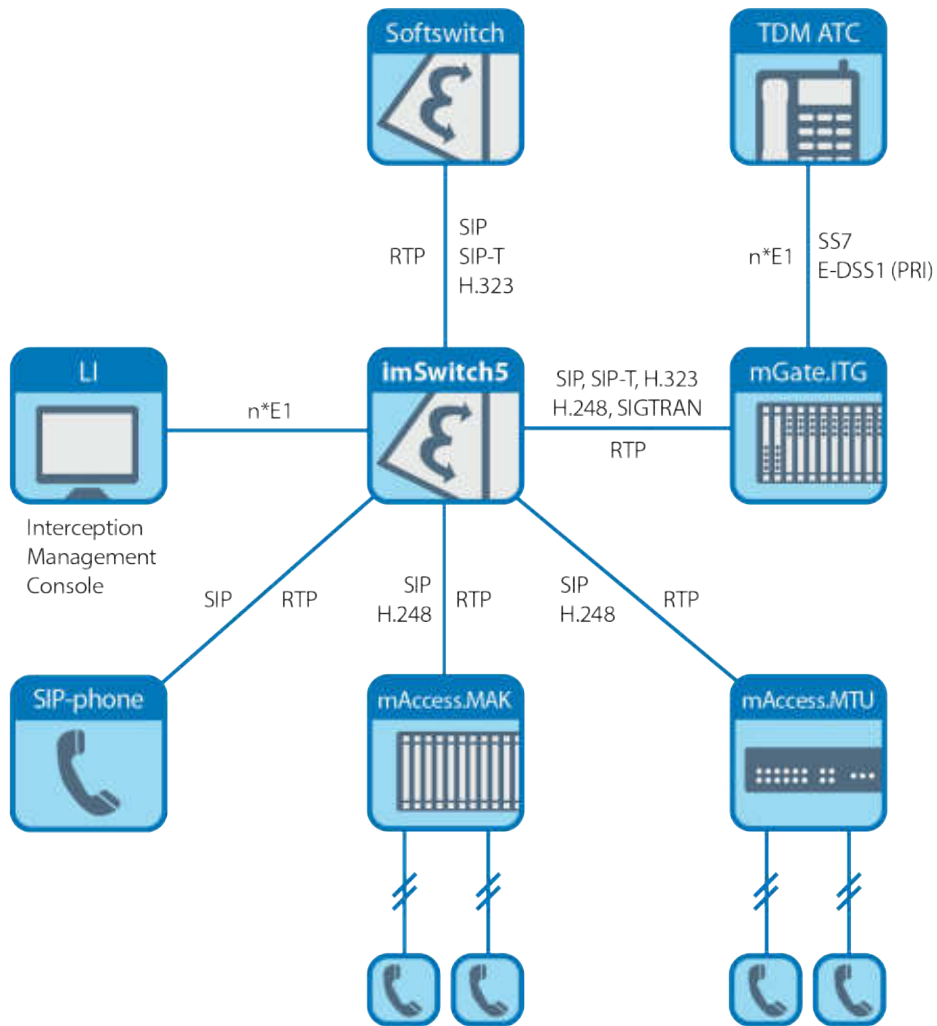

## ImSwitch5 Technical specifications

Number of subscribers	30 000 subscribers per dual-core CPU
System throughput	300 CAPS
Interface with packet-switched networks	Ethernet 100/1000 Base-T (IEEE 802.3)
Protocols for interaction with NGN networks	SIP, H.248/MEGACO, H.323
Protocols for interaction with billing/AAA systems	RADIUS, CDR sending via telnet/FTP/ SFTP / SCP
Maintenance	WEB-based administration kit, CLI via telnet/SSH, FTP, SNMP

# Softswitch class 4

Quality and reliability of the network depends directly on Softswitch choice. PROTEI Transit Softswitch class 4 solution is one of the most efficient options for development of NGN/IMS network. Due to support of a range of signaling protocols the system may be easy integrated to any types of networks and delivers any telecom services globally.

PROTEI imSwitch4 is a key element for building large NGN/IMS networks. It provides call routing through international networks and then transfers the information to class 5 softswitches and IP PBXs serving particular local areas for calls completion. The solution ensures VoIP carriers and international corporations benefit the most from installation of Softswitch class 4 that can deliver carrier grade VoIP services. A combination of Softswitch class 4 and 5 functionalities using the single hardware-software platform can reduce Operator's time and money expenses.

PROTEI imSwitch4 provides intelligent call routing and allows setting virtually any needed routing parameters.

## Key benefits

- Well-proven solution;
- Flexible increasing of system capacity;
- Intelligent load sharing and traffic distribution capabilities;
- LI functionality (can be adapted according to national requirements);
- Embedded LCR;
- API for Call Routing.

## Features

- Flexible advanced routing capabilities to provide high quality of VoIP calls and reduce cost for ex., SLA and CPS, LCR support;
- Powerful system of data collection and analysis for monitoring quality of service (QoS) according to various parameters (Call QoS, Voice QoS);
- Possibility to create routing trees basing on Calling Party and Called Party Numbers as well as many other parameters;
- Friendly User Interface for remote solution administration, monitoring and config management;
- Possibility to use External Routing APIs, which can create routing parameters and send them it to imSwitch4 via RADIUS;

Name	Status	Direction	Type	Inbound script	Outbound script	ASR	Connection	ACD
From_ABC	Enabled		All-directional					
IMS_Route	Enabled		Bi-directional					
IMS_128_179	Enabled		Bi-directional					
Office	Enabled		Bi-directional	Red_Sea_Office	In_Office_Script			
Office_4xx	Enabled		All-directional	IMS_P1				
R1	Enabled		Bi-directional					
R2	Enabled		Bi-directional					
R_170_98_177	Enabled		Bi-directional					
R_1999	Enabled		Inbound					
R_19990	Enabled		Outbound					
SBC_5000	Enabled		Bi-directional					
vpp1_test_1st	Enabled		All-directional					



- Compatibility with third-party NGN/IMS equipment (switches, media gateways);
- Establishing basic connections according to intellectual routing subsystem;
- Powerful CDR generation and statistics gathering subsystems for providing certain QoS;
- Support a wide range of signaling protocols for working with NGN and TDM networks (SIP, SIP-T, H.323, H.248/MEGACO, SIGTRAN);
- Key system element redundancy (Active/Standby);
- SIP interface for interaction with Application Servers;
- SNMP for alarm indication;
- RTP proxying.

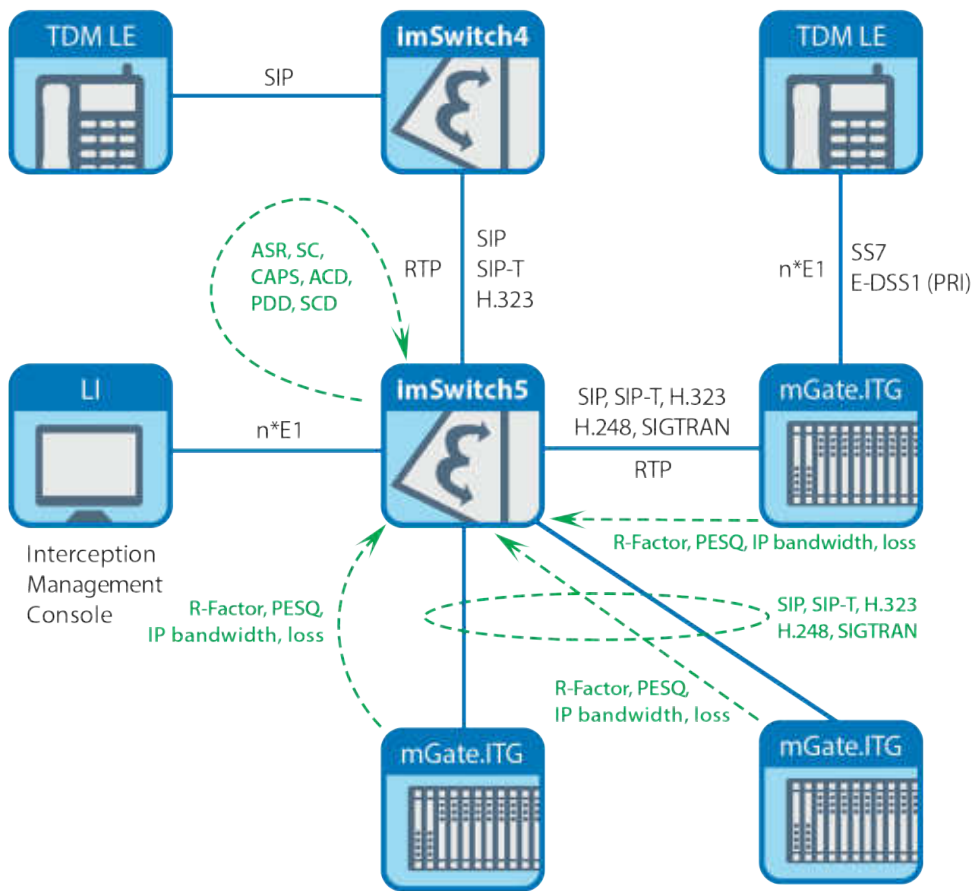

ImSwitch4 Technical specifications	
System throughput	500 CAPS per dual-core server
Interface with packet-switched networks	Ethernet 100/1000 Base-T (IEEE 802.3)
Protocols for interaction with NGN networks	SIP, SIP-I/T, H.248, H.323, SIGTRAN
Protocols for interaction with billing/AAA systems	RADIUS, CDR sending via telnet/FTP/SFTP/SCP
Maintenance	WEB-based administration kit, CLI via telnet/SSH, FTP, SNMP

## WEB-interface for Administration and Maintenance

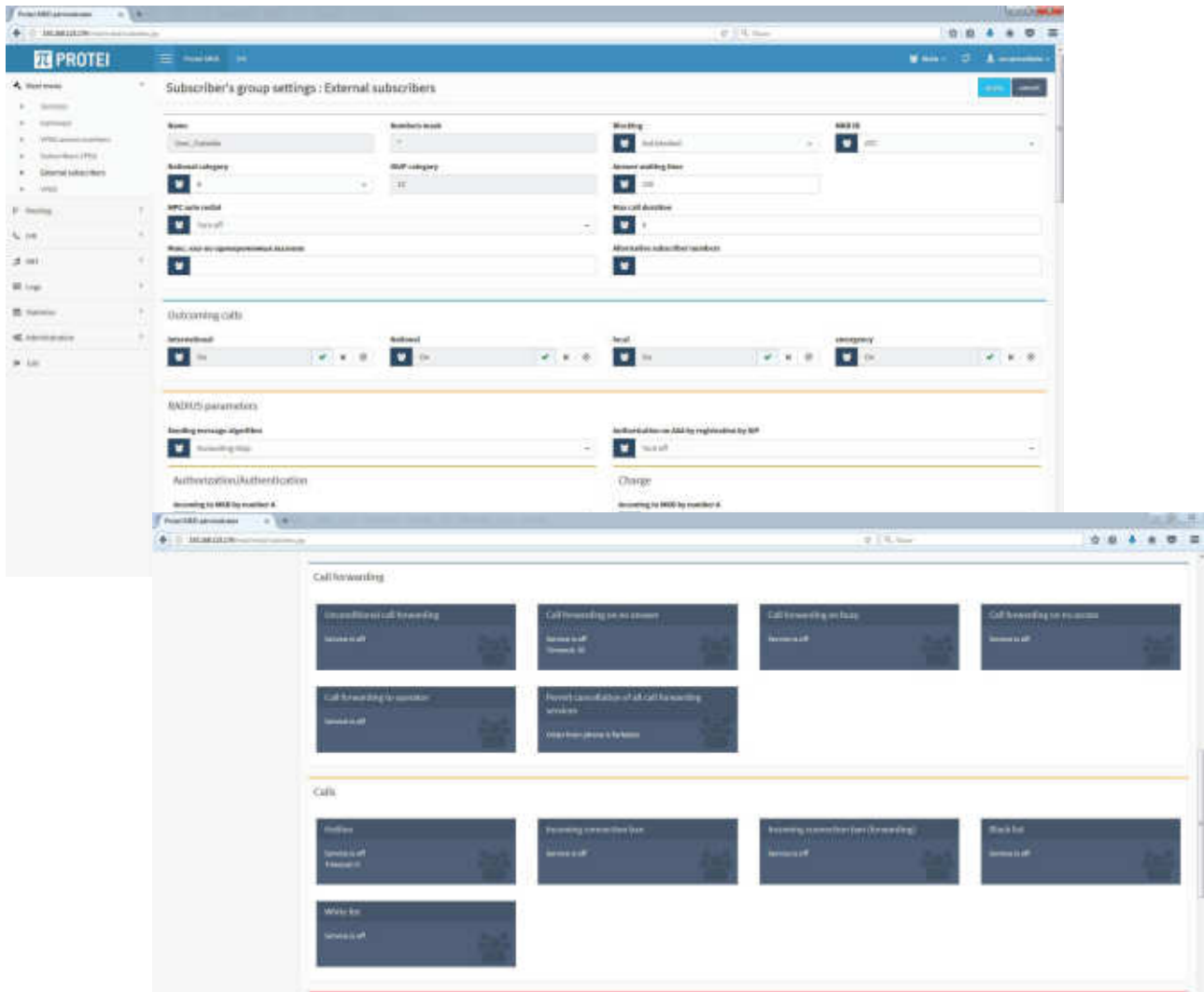

### Technical specifications

Hardware/software	Intel platform (x86_64); Mounting equipment – 1U or 2U high; Linux OS
Interface with packet-switched networks	Ethernet 100/1000 Base-T (IEEE 802.3)
Protocols for interaction with NGN networks	SIP, SIP-I/T, H.248, H.323, SIGTRAN
Protocols for interaction with billing/AAA systems	RADIUS, CDR
Fax	T.38, G.711
Codecs	H.264
Modem Mode	Transparent Transfer V.32, V.110
Integration	API for Subscriber profile management from external CRM/OCS
Maintenance	WEB-based administration kit, CLI via telnet/SSH, FTP, SNMP

# Medium Capacity PBX

imSwitch.PBX is great for businesses of all sizes. It's well-proven and scalable solution with wide functionality and flexible scalability meets all needs of any enterprises in contemporary PBX services. imSwitch.PBX Cometa.DS is a cost-effective solution that perfectly combines functionality of Softswitch and VoIP gateway in one device. It provides the ability of connecting subscribers via FXO, E1, or SIP to PSTN. With a compact form factor and wide capabilities, it provides an ideal solution for small to medium-sized businesses.

## Features

- Embedded call routing;
- Integration with different types of subscribers terminals (analog devices, IP-phones, etc);
- Computer telephony integration (CTI) support.
- Access control policy according to company structure;
- Geographically-Distributed Corporate Networks;
- LDAP support for corporate address book.

## Additional vPBX module

- Music on hold individual for each PBX;
- Individual IVR for each vPBX;
- Closed Numbering plan.

## Functionality

- Tone/announcement generation;
- Internal switching functionality;
- Flexible numbering;
- Different subscriber' categories support;
- SIP Register functionality for interaction with softswitches;
- Convenient remote administration tools: CLI, WEB-based interface, SNMP, FTP;
- IVR and music on-hold;
- Display name modification;
- Any type of numbering plans, multiple numbers for one subscriber;
- Hunt and pickup groups;
- Embedded call recording subsystem;
- Chat-room and multi-party conference;
- Auto-redial, auto call back;
- Black lists;
- Call transfer; Busy Line Function (BLF);
- Hot Dial/FDCI;
- Self-provisioning via WEB-cabinet.

ImSwitch.PBX Technical specifications	
Capacity	<ul style="list-style-type: none"><li>• Up to 2000 SIP devices;</li><li>• 24/48 FXS</li><li>• 6 FXO</li><li>• 1 /2 E1</li></ul>
Signaling protocols	SIP, H.248/MEGACO, SS7, EDSS1 (PRI), QSIG, H.323
Interfaces	E1, Ethernet 10/100 Base-T, 100 Base-FX
Codecs	G.711 A-Law, G.723, G.729
Fax	T.38, G.711
Power supply	48/-60 VDC or 220 VAC

# Trunk Gateway

PROTEI Trunk Gateway (ITG) enables efficient integration between NGN/IMS and TDM networks. This carrier-grade solution provides a wide range of functions, two hardware modifications and set of supported protocols allowing easy deployment in any network.

PROTEI Trunk Gateway can operate as an independent solution or complement PROTEI Service Platforms powering the deployment of interactive converged services over any bearer.

Basic call control procedures with DDI and CLIP/CLIR features are supported for incoming and outgoing calls.

Flexible routing subsystem enables to create different routing rules for different types of calls depending on incoming trunk, destination and/or origination number and bearer services being used.

The system hardware has in two versions 7U chassis or 1U compact unit 19".

## Features

- Efficient integration between NGN/IMS and TDM networks;
- Flexible call routing;
- Cluster solutions;
- Dense optical STM-1 interface;
- Scalability according to any Operator's needs;
- Convenient OAM tools;
- Compatibility with third-party equipment;
- Powerful CDR generation system;
- Maximum compatibility, reliability and performance;
- Data traffic and calls parameters accounting;
- Internal switching functionality;
- Hardware redundancy;
- Automatic module recovery (for example, in case of power failures);
- Effective echo cancellation algorithms.



Trunk Gateway Technical specifications	
Capacity	<ul style="list-style-type: none"><li>• Up to 96 E1 per chassis</li><li>• Up to 8E1 per 1U module</li></ul>
Number of SS7 links	Up to 8 per card
Interface	E1, G.703, 120 Ohm symmetrical, STM-1 (SDH)
Signaling protocols	SIP, SIP-T, SIP-I, H.323, SIGTRAN, H.248; SS7, DSS-1, R2, R1.5 (Russian 2CAS), QSIG
Codecs	G.711, G.729, G.726, AMR
Fax	T.38, G.711
Modem	V.32, V.110
Dimensions	19" rack mountable, 1U (up to 8E1) or 7U (up to 96E1 per chassis, easy scalable)
Maintenance	WEB-based administration kit, CLI, Telnet/SSH, FTP, SNMP.

# High-capacity Access Gateway

PROTEI mAccess.MAK is cost-effective NGN access solution. By supporting a wide range of network technologies, the system provides seamless transition from circuit-switched networks to NGN/IMS infrastructure.

Using PROTEI mAccess.MAK ensures subscribers access to all advantages of IP world without reference to existing networks and provides ISDN functions and VAS-services to users with maximum results in minimum time.

PROTEI mAccess.MAK has a modular structure and can be equipped with various interface boards in any combination depending on Customer's needs. Such the architecture simplifies process of expanding and upgrading the system without interruption of service providing and gives a great opportunity for installing a high-capacity system up to 5472 subscribers' lines in one 42U rack.



## Key benefits

- Cost-effective solution for creating NGN/IMS access infrastructure;
- Low energy consumption;
- Convenient maintenance and administration tools;
- Easy integration with network elements.

## Features

- Embedded simple call routing functionality;
- Internal switching functionality;
- Flexible numbering;
- Different subscriber' categories support;
- SIP Register functionality for interaction with softswitches;
- Convenient remote administration tools: CLI, WEB-based interface, SNMP, FTP;
- System monitoring and CDR logging;
- SNMP support;
- Highly flexible, scalable platform;
- Interaction with WEB-application's server.

## mAccess.MAK Technical specifications

Capacity	<ul style="list-style-type: none"><li>• 48 analog lines per card</li><li>• Up to 912 analog lines per 7U chassis</li><li>• 16 BRI subscribers per card</li><li>• 30 FXO ports per card</li></ul>
Signaling protocols	SIP, H.248, SS7, DSS-1 (PRI), R2, R1.5 (Russian 2CAS), QSIG, H.323
Codecs	G.711 A-Law, G.723, G.729
Fax	T.38, G.711
Administration, configuration management and maintenance	WEB-based administration kit via secure connection, CLI, telnet/SSH, FTP, SNMP

# Small-capacity Access Gateway

PROTEI mAccess.MTU is a subscriber gateway specially designed for providing network services for smaller scopes, such as offices and residential applications. The gateway is scalable from 2 to 48 analog ports and connects analog terminals or PBXs to IP network using FXS or PRI Interfaces.

PROTEI mAccess.MTU allows providing subscribers with traditional telephony as well as new-generation Triple Play services. Supporting by the system such protocols as SIP, H.248/MEGACO enables flexible deployment and interoperability with the evolving NGN-networks. It can be effectively used with PROTEI softswitches as well as with third-party equipment.

## Key benefits

- Fast and simple network building;
- Compact 1U 19" module;
- Compatibility with third-party equipment;
- Cascade mode support;
- Low outlay, high returns.

## Features

- Internal switching functionality;
- Call routing;
- Tone/announcement generation;
- Transmission/receipt of DTMF tones;
- Different types of ringing signals support;
- Ability to set on-hold the remote side;
- PRACK method support;
- Locating SIP servers support;
- Registration support.

mAccess.MTU Technical specifications	
Number of Analog Two-wire Interfaces	24/48 ports per module
Signaling protocols	SIP, H.248
Interfaces	E1, Ethernet 10/100 Base-T, 100 Base-FX
Codecs	G.711 A-Law, G.723, G.729
Fax	T.38, G.711
Power supply	48/-60 VDC or 220 VAC

# Session Border Controller

SBC (Session Border Controller) is one of IP-network key element intended for protecting the internal networks based on NGN/IMS architecture.

PROTEI-SBC is a software complex designed for subscriber access management and carriers interaction in VoIP network of fixed or mobile Operators. It can guarantee effective protection of IP-network core and provide a wide range of additional features required at the access level, including flexible traffic management, redundancy and QoS. SBC performs the functionality of session border controller in a multi-service network and routes VoIP calls from external IP-networks to the switching core. It is based on current IT-technologies and can work with any IP terminals and devices.

PROTEI-SBC provides in two modifications - I-SBC (works between telecom networks) and A-SBC (functions between the carrier network and the end user).

**I-SBC** is a session border controller that works between networks. It includes IBCF, TrGW (IBGF), IMS-ALG/IMS-AGW functions in IMS-architecture.

## Functionality:

- Signalling and media data processing and transfer;
- Modification of fields in signalling messages;
- Topology concealment (THIG);
- Codecs Transcoding: G.711 A/ $\mu$ -Law, G.722, G.722.2(AMR-WB), G.723.1, G.729 A;
- Restriction of bandwidth;
- Firewall functions - static and dynamic access control;
- Support of SIP/SIP-I/SIP-T protocol;
- Licensing on number of simultaneous sessions, connection attempts per second, sessions with transcoding;
- Timers control for media traffic;
- Trace files generation;
- Embedded tools for established connections monitoring;
- CLI for administration;
- Alternative routes, load balancing;
- Support of Ethernet interfaces, 802.1q VLAN IPv4 and virtual interfaces;
- CDR generation and SNMP monitoring.

**A-SBC** is a session border controller that works between the carrier network and end users. It includes P-CSCF, E-CSCF, IMS-ALG/IMS-AGW functions in IMS-architecture.

## Functionality:

- Signalling and media data processing and transfer;
- Modification of fields in signalling messages;
- Topology concealment (THIG);
- Codecs Transcoding: G.711 A/ $\mu$ -Law, G.722, G.722.2(AMR-WB), G.723.1, G.729 A;
- Licensing on simultaneous sessions number, connection attempts per second, sessions with transcoding;
- Timers control for media traffic;
- Ability to work in the virtual environment or on physical servers;
- Trace files generation;
- Cluster reservation, active registrations and calls recovery;
- Tools for established connections;
- CLI support for administration;
- Alternative routes, load balancing.

## Key benefits

- All completed solution for maintaining secure SIP trunks and user access;
- Unified platform that combines the SBC and media controller;
- Effective tool for reducing costs, space and power consumption;
- Support a wide range of third-party IP devices;
- Powerful system of interaction and support SIP normalization functionality;
- Support for routing mechanisms to for seamless interconnection of networks;
- Protection of the external interface from DoS-attacks, fraud and interception via IP;
- QoS management for VoIP;
- Backup mode support;
- Horizontal scaling.

# Integrated Monitoring System (DevMon)

DevMon is a convenient tool for monitoring of all network elements in real time mode. Using of DevMon can view both the whole picture of network and detailed information about any device in it. The data can be presented in real-time and received from the archive for keep analysis.

## Key Benefits

- Collection and processing data from a variety of sources;
- Unlimited number of information sources;
- Compatibility with different vendors' equipment;
- Easy integration with the network;
- User-friendly WEB-interface and events visualization;
- Embedded reporting tools;
- Continuous monitoring of network elements with current status notification;
- Viewing and analysis the complete picture of events.

## Functionality

- Collecting information and display the picture of events in general, status of engineering systems and equipment, incidents in one information window;
- Creating the database on events, their consequences and measures on the elimination;
- Processing and response to events from building management systems (BMS);
- Registration and tracking messages status about all types of incidents (BMS infrastructure incidents, transport accidents, fires, crimes, etc.);
- Creation reports on events;
- Access policy management.





# Integrated WEB-administration

PROTEI develops an advanced WEB-administration subsystem for collecting and storing call records processed by network equipment. It is also intended for outputting data to a graphical user interface and generating reports for sending to e-mail and Telegram. The system allows viewing statistics on services in a convenient form and greatly simplifies the analysis of call processing in the network as a whole.

For maximum efficiency the subsystem can be used in a combination with Integrated Monitoring System (DevMon) developed by PROTEI. With the WEB-administration subsystem statistics gathering and reports on processed traffic generation becomes an easy effective procedure. The ability to set any combination of parameters allows system users to quickly track possible "bottlenecks" in the network and plan their elimination for maintaining the required QoS.

The system user needs only a PC with pre-installed CDR Viewer software for accessing CDR Viewer Web-interface.

## Functionality:

- Interaction with network equipment via sftp protocol;
- Collecting CDR records on incoming calls and storing them in the file system;

## Key benefits

- Advanced statistics and reporting application;
- Easy deployment and integration with network elements;
- Data export to e-mail or Telegram;
- Fully compliance with PROTEI DevMon;
- Access management;
- Wide range of supported interfaces.

- Providing a web interface for authorized users to manage call records and statistics;
- Filtering records by specified parameters;
- Flexible configuration of call logs and statistics templates;
- Export records from the system to the local user terminal;
- Sending reports of the collected records and trigger events to e-mail or Telegram;
- Setting the following parameters for each network element: ID, Date, Time, CallID, Incoming GW, Outgoing GW, Signaling type, CgPN, CdPN, OdPN, RgPN, Redirection Cause, Redirection Counter, CgPC, Name incoming gateway and others;
- Supporting of sftp, Jdbc, HTTP/json, HTTP/xml and SMTP interfaces.

The screenshot displays a web-based interface for managing call records. The main area contains a table with columns for various parameters such as ID, Date, Time, CallID, Incoming GW, Outgoing GW, Signaling type, CgPN, CdPN, OdPN, RgPN, Redirection Cause, Redirection Counter, CgPC, Name incoming gateway, and others. The table is populated with multiple rows of data, each representing a call record. The interface also includes a sidebar with navigation options and a top navigation bar.

# Our customers



## HEAD OFFICE

KOPLI t.81-11/12, 11712 Tallinn

VABARIIK Estonia

Tel.: +372 56 935 699

E-mail: [sales@protei.com](mailto:sales@protei.com)

Website: [www.protei.com](http://www.protei.com)

## MENA Branch

Wasfi AL Tal St. 98 Al Otoum Business  
Center Suite 205

P.O Box 961741 Amman 11196 Jordan

Tel.: +962 6 560 78 33

E-mail: [sales@protei.me](mailto:sales@protei.me)

Website: [www.protei.me](http://www.protei.me)